

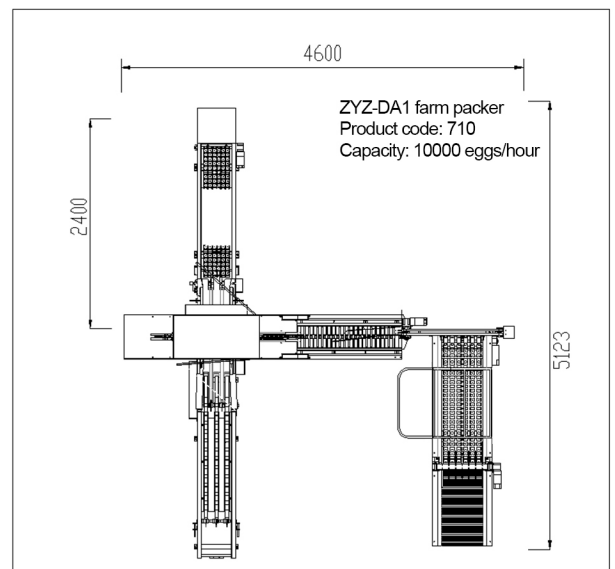

## 710 FARM PACKER

### FEATURES:

- ◆ **Accumulator:** Eggs from egg shed enter into accumulator, which will direct 6 lines of eggs into 1 line and transport them to the single conveyor nicely with no cracking.
- ◆ **Candling booth:** 6 rows LED lights are added under the accumulator and workers can pick out any leaking, dirty or cracking eggs through the LED lights. The LED candling booth equips with cover and mirror as well to reinforce the candling result.
- ◆ **Auto head turning:** Simple design which makes sure the eggs are perfectly orientated with the bigger head (air chamber) on top for longer storage before getting packed.
- ◆ **Automatic packing lane:** Including single dropset and manual egg tray stoker. Empty trays must be manually placed in the egg tray stoker, allowing the stoker to send the empty trays to where the eggs will drop from. the single dropset unit drop down the eggs into 30-egg tray automatically.



### TECHNOLOGY PARAMETER

Model	ZYF-DA1
Product code	710
Capacity	10000 eggs/hour
Power	1.9KW, 50HZ
Voltage	380V, 3-phase
Dimension (L* W* H)	5.1*4.6*2M
Functions	Accumulator, candling booth, Auto head turning, automatic packing lane

